



## ENDURO 175 ICE DRINK DISPENSER



### FEATURES

**Merchandising** - Highly efficient LED illuminated merchandiser utilizing a brighter, longer lasting bulb, providing a high impact visual display

**Quality** - Built-in cold carbonator produces bottle-quality drinks every time

**Low Maintenance** - No seasonal CO<sub>2</sub> adjustments required for changes in water temperature

**Simple** - A complete system for simplified installation reduces service frequency and lowers equipment life cost and generates increased beverage sales and greater consumer satisfaction

**Intelligent** - Ice used to cool cold plate kept separate from ice dispensed into cups

**Durability** - One piece ABS thermoformed plastic ice storage hopper. Durabide™ design provides durability and ensures all ice in the hopper is dispensable

**Flexible** - Unit readily accepts top mount cubers with manual ice fill capability

**TotalFlex™** - Equipped with TotalFlex™



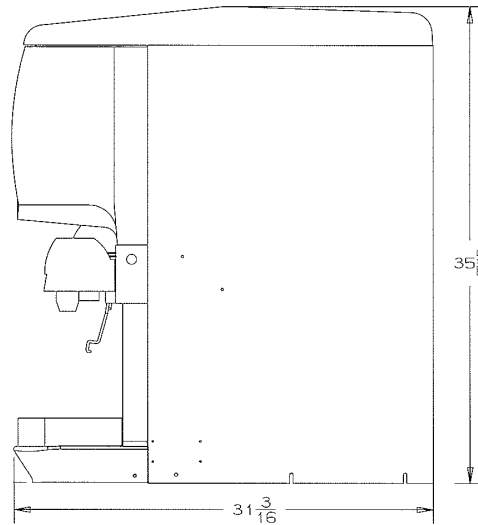
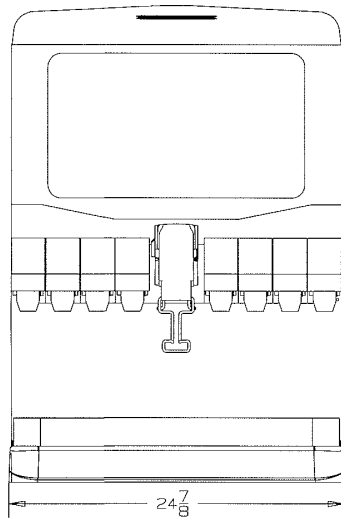

**NOTE: PUMP & MOTOR ASSEMBLY  
MUST BE POSITIONED WITHIN  
8 FEET OF THE DISPENSER**

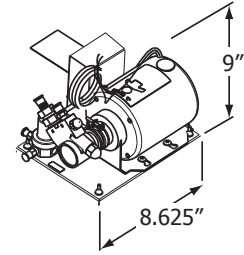

PART NUMBER	DESCRIPTION
621053702	Enduro 175 IntelliCarb dispenser with 8 UFB-1™ 2-4 oz Sanitary Lever valves, 120 V / 60 Hz
621053701	Enduro 175 IntelliCarb dispenser with 8 UFB-1™ 2-4 oz Push Button valves, 120 V / 60 Hz
621053704	Enduro 175 IntelliCarb dispenser with 8 UFB-1™ 2-4 oz Optifill™ valves, 120 V / 60 Hz
3470	Stand for Enduro 175

See price book for ice maker adapter kit.

## TECHNICAL SPECIFICATIONS

TYPE OF VALVES . . . . . UFB-1™ 2-4 oz / sec post-mix

NUMBER OF VALVES . . . . . 8

BEVERAGE MANIFOLDING . . . . . TotalFlex™

CUP CLEARANCE . . . . . 10" (254 mm)

GRAPHIC DIMENSIONS . . . . . Overall:  
11.1"H x 19.3"W  
Viewable:  
10.6"H x 18.7"W

ICE STORAGE CAPACITY . . . . . 175 lb (79.4 kg)



CONNECTIONS . . . . . Water: 0.375" (9.5 mm) barb fitting  
Syrup: 0.375" (9.5 mm) barb fitting

STANDARD FEATURES . . . . . Beverage key switch timed ice agitation and 4" legs

DRAIN SIZE . . . . . 0.75" pvc (npt) pipe or 1" (19.1 mm) pvc (npt) pipe or flexible tubing 25.4 cm flexible tubing

ELECTRICAL REQUIREMENTS . . . . . 120 V / 60 Hz / 3 Amps or 220 V / 50/60 HZ / 2 Amps

SHIPPING WEIGHT . . . . . 275 lb (124.7 kg)

AGENCY LISTINGS . . . . .     
City of Los Angeles

Pepsi and IntelliCarb are registered trademarks of Pepsi Co, Inc.

